

BUNDIT

A Stacker Bundler Machine

Complete solution for fully automated bundling of stacks (packs) of baby wipes or other packages such as snacks, chocolate bars and more



MAIN MODULES

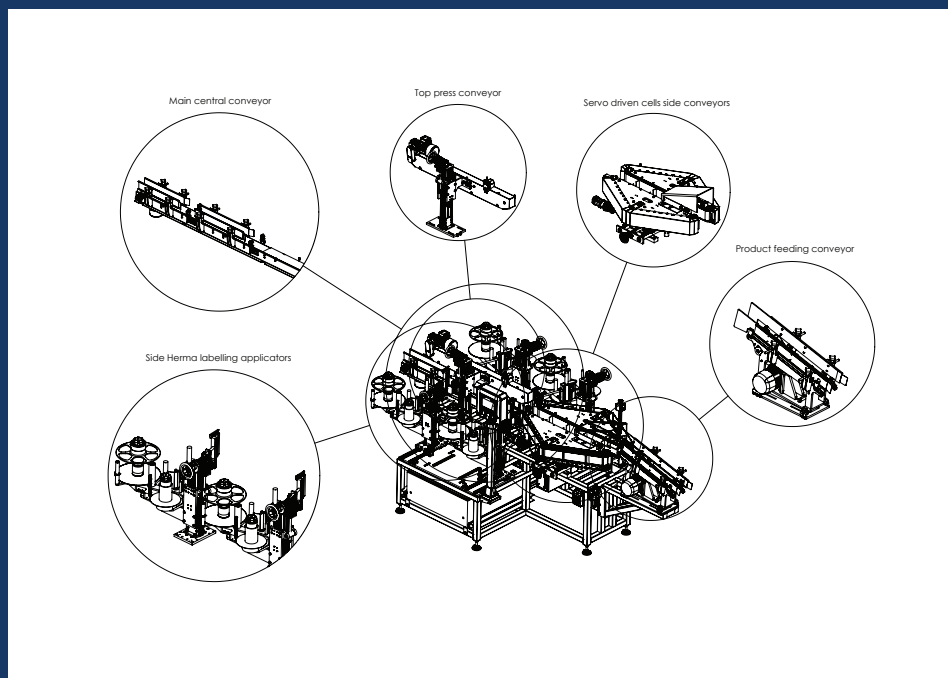

THROUGHPUT

- Up to 150ppm in bundles of 2,3,4 or 5

PRODUCTS

- Baby wipes, snacks, chocolate bars and more

CONTINUOUS WORK

- Four (4) alternate Herma-made labeling applicators, two on each side

STANDARD SPECIFICATION

- Industry 4.0-ready
- SIEMENS PLC and HMI Control
- Herma label applicators
- Construction materials: SST304 Structure
- E-stop buttons
- CE, ANSI, OSHA, NFPA and NEC compliant
- Tool free and quick changeover time
- Easy, cost-effective maintenance

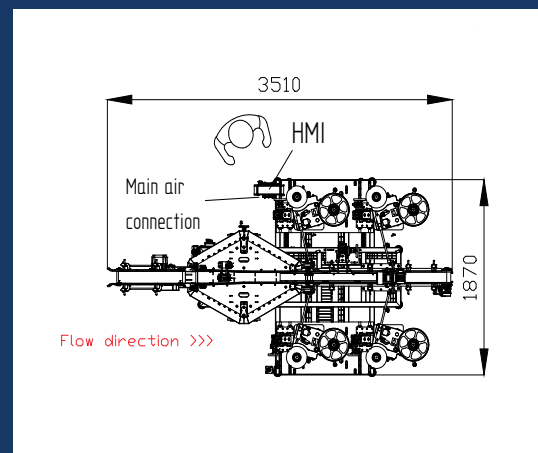

  **Designed for minimum space requirements**

INDUSTRIES

- Nonwovens, food and beverage, cosmetics, pharmaceuticals, chemicals and more

FOR MORE DETAILS – CONTACT US:

 sa@shemeshautomation.com

(UK) +44 758 428 1707
(US) +1 920 325 0050
(IL) +972 3 550 9946
(FR) +33 6 1521 0409

 www.shemeshautomation.com