

EXANE

SEMESH AUTOMATION
PRUDENT PACKAGING SOLUTIONS



Advanced Automatic Inverting Air Rinsing

- **Speed:** Models offered with throughputs of 30, 60 and 100 containers per minute
- **Sub 15-minute tools-free change over**
- **Optional filter upgrades available**
- **Modest small-scale footprint**
- **Seamlessly integrates with the rest of the Shemesh product portfolio across front, core and end of line equipment**



Let us build your vision

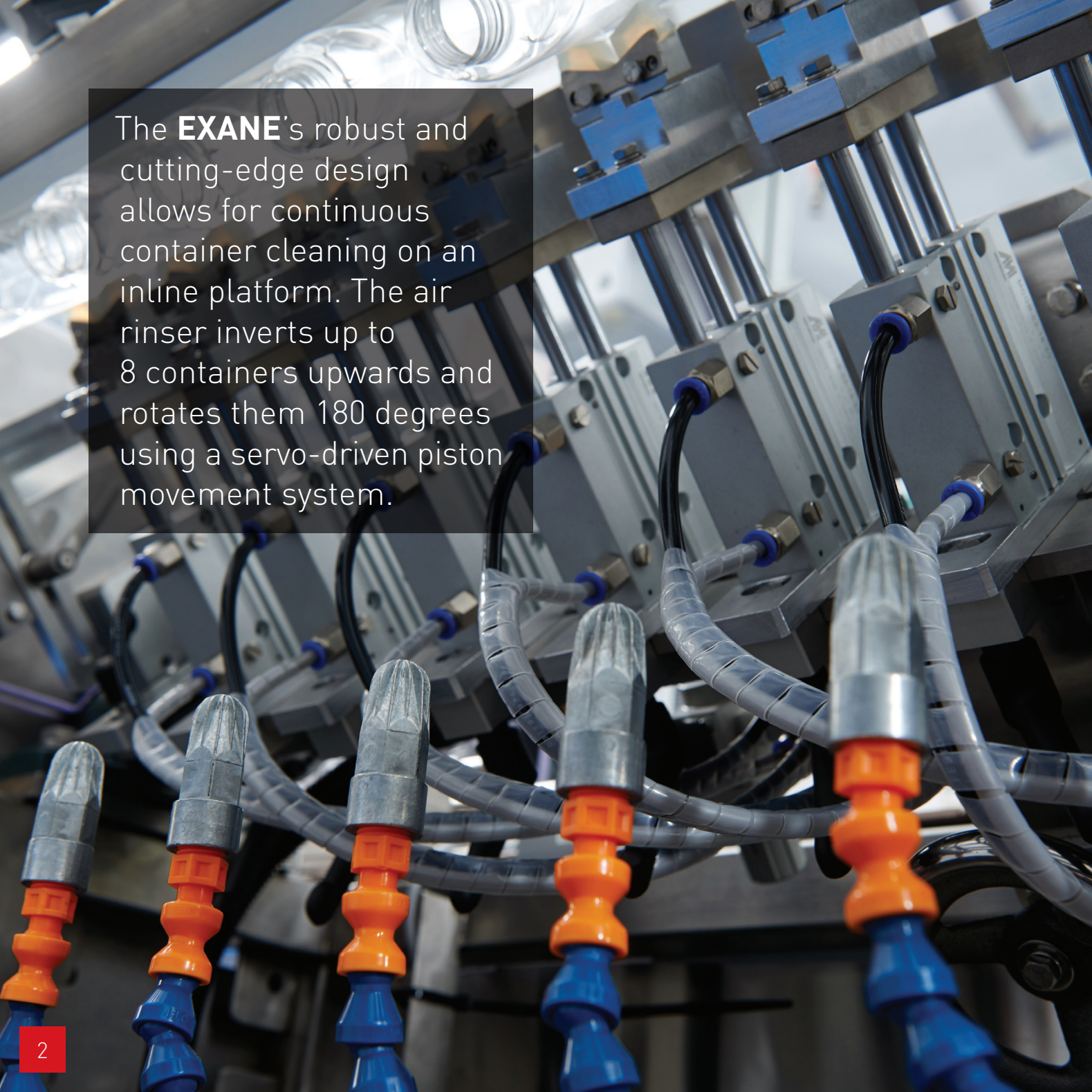

The **EXANE**'s robust and cutting-edge design allows for continuous container cleaning on an inline platform. The air rinser inverts up to 8 containers upwards and rotates them 180 degrees using a servo-driven piston movement system.

EXANE

The **Exane** is a must-have addition to any food & beverage production line. Whether it's plastic metal or glass containers, the **Exane** offers

exceptional hygiene standards by cleaning each container before it progresses to the other machines in the line.



Quick fact sheet

- **Fully automatic**
- Speed: Different models offered in **30, 60** and **100 products/minute** variants
- **Sub 15-minute** tools-free change over
- Complete **304 stainless steel** machine design
- Supports oval, round and other shaped containers
- Suitable for plastic, glass and metal containers
- Standard or **enhanced air filters** available
- Explosion proof and corrosion proof upgrades available
- Sanitary design
- Optional **vacuum enhancement**
- **Quick** and **easy to clean, maintain** and **set-up** for different product sizes
- Seamlessly **integrates** with the rest of Shemesh Automation's product portfolio across front, core and end of line equipment

STANDARD SPEC

- **Industry 4.0** ready
- **Festo (Germany)** pneumatics and servo systems
- Complete **SST304/316L** design
- **FDA** approved piping as applicable
- **Siemens (Germany)** PLC & HMI and motors. Allen Bradely – optional
- **Banner** sensors
- **E-stop** buttons and safety interlocks wired through **CAT IV** safety controller
- **CE, ANSI, OSHA, NFPA** and **NEC** compliant

OPTIONAL

Three-phase micron-level filter, as follows:

- First filter layer for solids and oil: **5 microns**
- Second Filter layer for oil fumes: **0.01 micron**
- Third filter layer for active carbon: **0.003 microns**
- **Two-year** filter lifecycle!

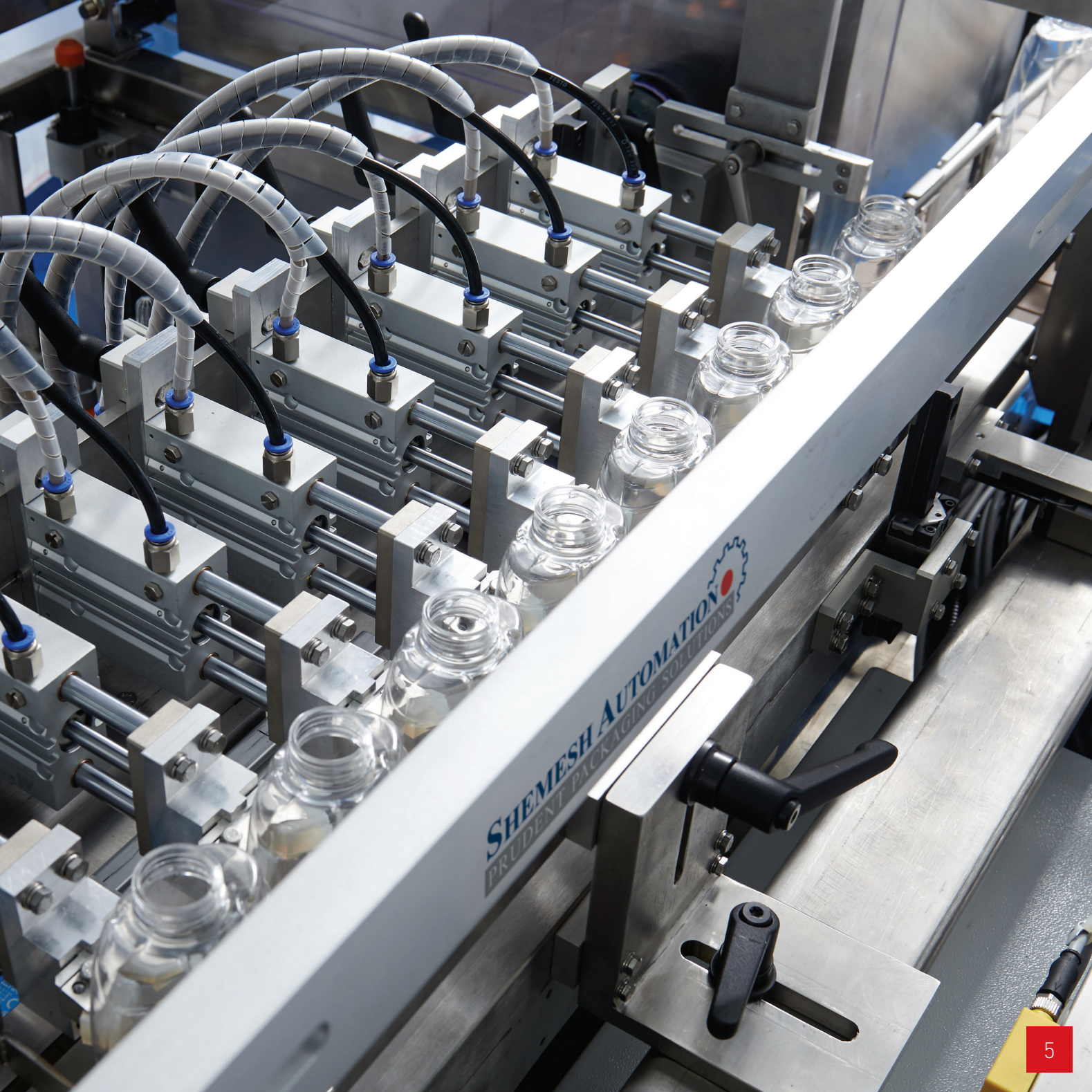

SHEMESH AUTOMATION
PRUDENT PACKAGING SOLUTIONS



Suitable for cleaning round, oval or custom containers, the **Exane** boasts the Shemesh DNA throughout its superb design and guarantees consistent, accurate production throughout its working life.



EXANE – Key modules

EXANE Layout

- 1 Manipulator with grippers to hold and rotate the bottles
- 2 Array of air jets to blow clean compressed air
- 3 Main stainless steel conveyor
- 4 Pneumatic separator to separate bottles into batches
- 5 Optional (not shown) 3-phase micron level filter

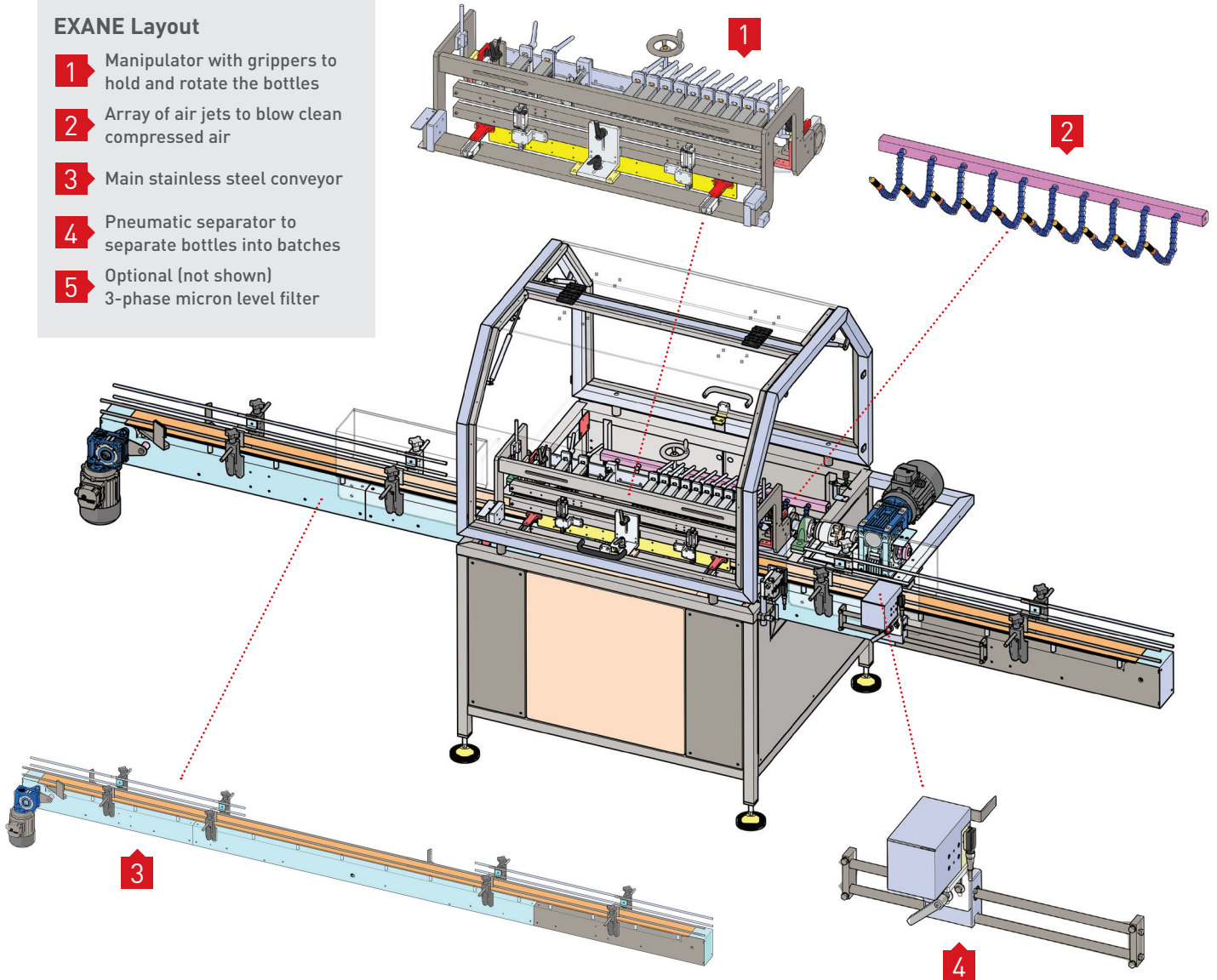

Basic indicative **EXANE** layout

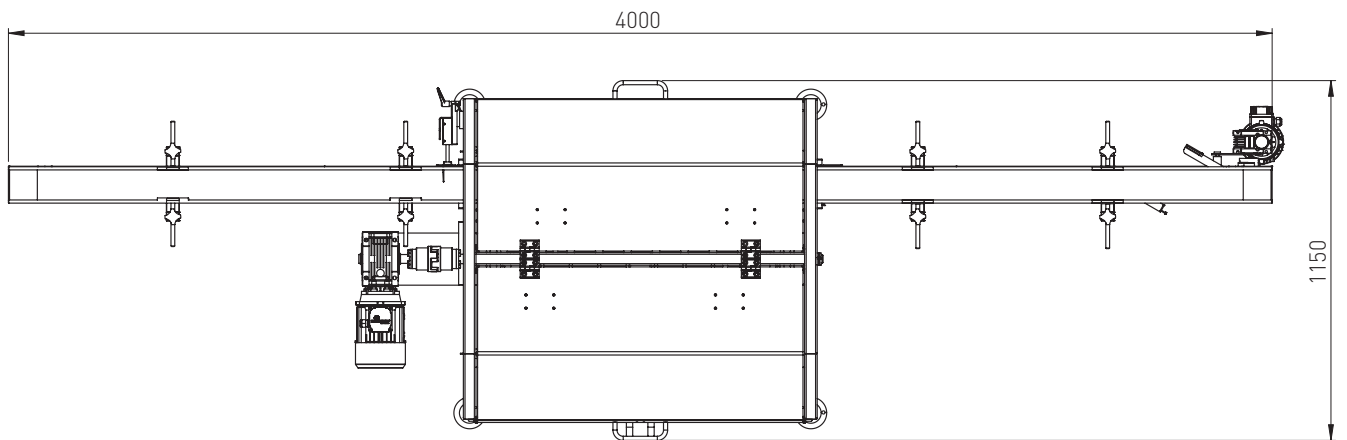
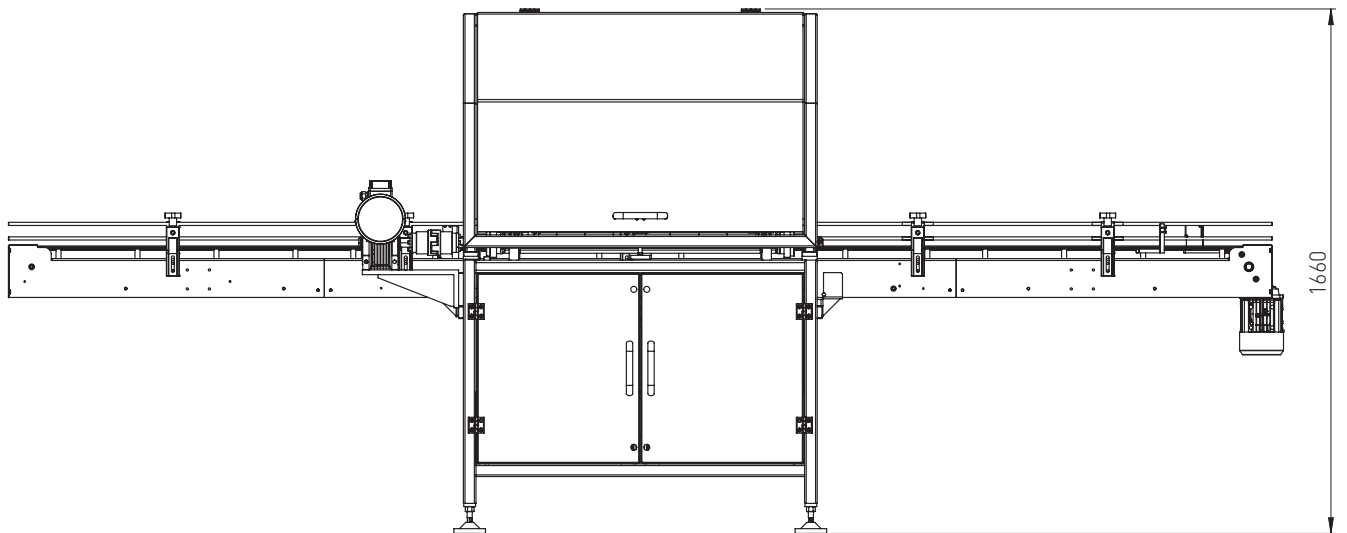



“Our people have driven Shemesh Automation’s success for over 30 years through sustained, superb execution across a range of markets and products.”

Shai Shemesh, President

“Shemesh Automation works closely with its customers to unlock maximum productivity, operational flexibility, long term reliability, safety and efficiency. This, coupled with world-class engineering and out of-the-box mindset, is key to everything we do.”

Eli Shemesh, Founder

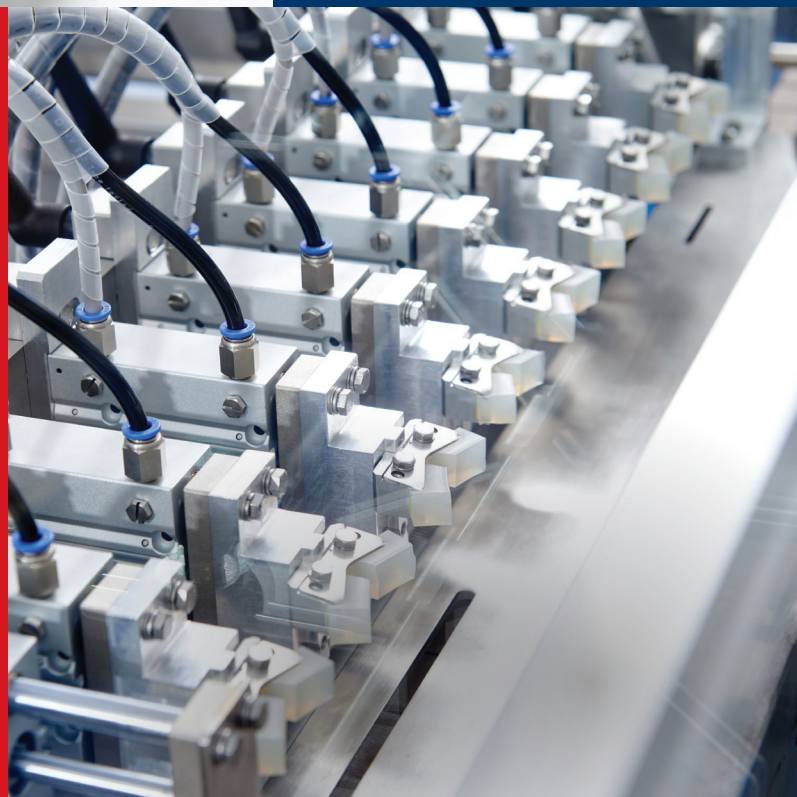



Global presence



Wisconsin, USA

North America HQ

State-of-the-art machine showroom, sales and after-sales support, spare parts inventory and North American logistics centre.

Hampshire, UK

Global Headquarters

CEO's office, Marketing, Strategy, Business Development and Finance.



Semur-en-Auxois, France

European HQ

French team, Tech centre featuring state-of-the-art machinery showroom, sales and after-sales support and European logistics centre.

Tel Aviv, Israel

R&D and Manufacturing

Operations, R&D, Engineering and Manufacturing.



WORLDWIDE

15

International branches

- United Kingdom
- North America
- France
- Latin America
- Israel
- Spain
- United Arab Emirates
- South Africa
- India
- China & Hong Kong
- Japan & Indonesia
- Australia & New Zealand

Over

1800

machines...

CAPACITY

x2

Manufacturing sites

...supported in over

30

countries

6

Trade shows per year

Global representation

Shemesh Automation collaborates with teams on complex Fortune 500 projects and has gained not only a proven and trusted network to put at your disposal, but also invaluable knowledge to help drive your projects.

We share our expertise to guarantee the maximum productivity of your machinery. Our global network of sales representatives and After Sales service specialists offer you flexible and efficient support. Our highly-qualified technicians ensure a fast solution whenever and wherever you need it.

REGIONAL HEADQUARTERS

United Kingdom

Shemesh Automation UK Ltd
Contact: Mr. Carl Gunaratnam

North America

Shemesh USA Inc
Contact: Mr. Jim Livermore

France

Shemesh Automation France
Contact: Ms. Nelly Desbiens

Israel

Shemesh Automation Israel Ltd
Contact: Mr. Luis Coronel

OTHER OFFICES

Spain

Shemesh Spain
Contact: Ms. Leticia Mulet

United Arab Emirates

Shemesh Automation UAE
Contact: Mr. Johann Van Niekerk

South Africa

Shemesh Automation SA
Contact: Mr. Simon Daniels

India

Shemesh Automation India
Contact: Mr. Shilpan Patel

China & Hong Kong

Shemesh Automation Asia
Contact: Mr. Charles Yip

Japan & Indonesia

Shemesh Automation Japan & Indonesia
Contact: Mr. Kentaro Taguchi

Australia & New Zealand

Shemesh Automation Australia
& New Zealand
Contact: Mr. Cameron McKenzie

LATIN AMERICA

Contact: Mr. Nir Baram

GLOBAL SALES

Contact: Mr. Luis Coronel



ATEX



ANTI-CORROSION

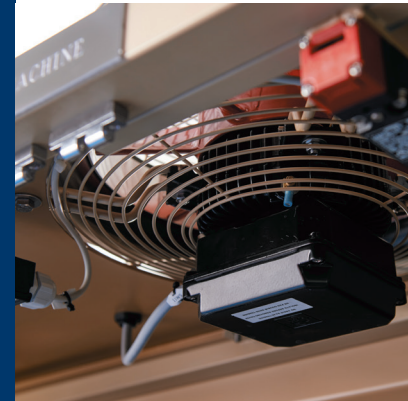

For all sales enquiries please contact us via sales@shemeshautomation.com

Explosion proofed & Corrosion proofed

Corrosive or alcohol-based solutions dictate that your equipment is duly fitted to professionally handle these delicate environments. Years of experience in the field made it possible for us to tailor for you the exact protection so your production is safe and stable while your people and equipment are well protected keeping your facility at the top of the range.

All of our machines are constructed using SST 304/316L, and are available with anti corrosive proprietary coating. As well as the machine base, all vital parts such as nozzles and pumps are also specially treated.



Offices:

United Kingdom

Shemesh Automation UK Ltd
85 Great Portland Street
First Floor
London W1W 7LT
United Kingdom
Tel. +44 758 428 1707



USA

Shemesh USA Inc
1040 Centennial Street
Green Bay
Wisconsin 54304
United States
Tel: +1 920 325 0050



Israel

Shemesh Automation Israel Ltd
4 Ha-Sar Khayim Moshe
Shapira St.
Rishon Lezion 7570406
Israel
Tel. +972 3550 9946



France

Shemesh Automation France
Bopak SARL Building
10 Rue de la Croix Belin
Semur-en-Auxois 21140
France
Tel. +33 (0) 615 210 409



www.shemeshautomation.com



Let us build your vision