

SA-JF

SHEMESH AUTOMATION
PRUDENT PACKAGING SOLUTIONS



Fully-automatic jar feeder for various types of different shaped containers

- Throughputs from 40 to 200ppm
- Multiple product orientation available depending on product shape/needs
- Built-in quality control & defects reject system
- Tool-less sub 10 minutes changeover
- Jar cleaner air jet available as add-on

OVER **30** YEARS OF EXCELLENCE

Let us build your vision

APPLICABLE FOR:

- Pharma & Biotech
- Food & Bev
- Cosmetics,
Health & Beauty
- Chemicals



SA-JF Jar feeder

The flexible **SA-JF Jar Feeder** is designed to fit various types of different shaped plastic containers – square, oval or round. Different models applicable for speeds of up to 200ppm.

The fully synchronized container feeder reduces the need for manual operation and vastly improves the speed of your line.



Quick **fact sheet**

Benefits & features

- **Fully automatic**
- **Multiple product orientations available depending on product shape and needs**
- **Tool-less sub 10 minutes changeover**
- Speed: throughputs **40-200ppm**
- **Jar cleaner air-jet** add-on available
- **Applicable to plastic containers of most common shapes and sizes**
- **Sanitary** welding, design and build standard
- Built-in **quality control** reject system
- **Explosion proof** and **corrosion proof** models available
- **Easy** and fast to **clean and maintain, format changeover**
- Compatible and seamlessly integrates with the rest of Shemesh's product portfolio

STANDARD SPEC

- **Industry 4.0** ready
- **Festo (Germany)** pneumatics and servo systems
- Complete **SST304/316L** design
- **FDA** approved piping as applicable
- **Siemens (Germany)** PLC & HMI and motors. Allen Bradely – optional
- **Banner** sensors
- **E-stop** buttons and safety interlocks wired through **CAT IV** safety controller
- **CE, ANSI, OSHA, NFPA** and **NEC** compliant



“Shemesh Automation is one of my favourite suppliers. Not only is their equipment reliable and innovative, but the people behind this name have also managed over the years to prove to us loyalty and service rarely seen in the industry.”

Gabi Cherniak, Senior Project Manager,
Teva Pharmaceuticals Industries.



How the SA-JF Jar Feeder works

- 1 Empty jars are loaded into the hopper which has level transmitters for 'half-full' and 'empty'
- 2 The slat elevator picks up the jars from the bottom of the hopper and transfers them to the disc sorter (first orientation)
- 3 The disc sorter orientates the jars so that they open facing upwards, with the opening rim at the top (second orientation)
- 4 The jars enter the exit conveyor in the perfect position
- 5 On the way to the next station, the spiral nozzle (optional) blows air into the jar to discharge particles.



SA-JF is SST304 made and features high spec components including Siemens motors, HMIs and PLCs as well as Festo servo systems and is Industry 4.0 ready.



SA-JF's built-in QC and reject system verifies that every product leaving the machine is properly lidded.

SA-JF - Key modules

SA-JF Jar Feeder Layout

- 1 Hopper
- 2 Slat Elevator
- 3 Centrifugal Feeding Plate
Disc Sorter
- 4 Conveyor Belt

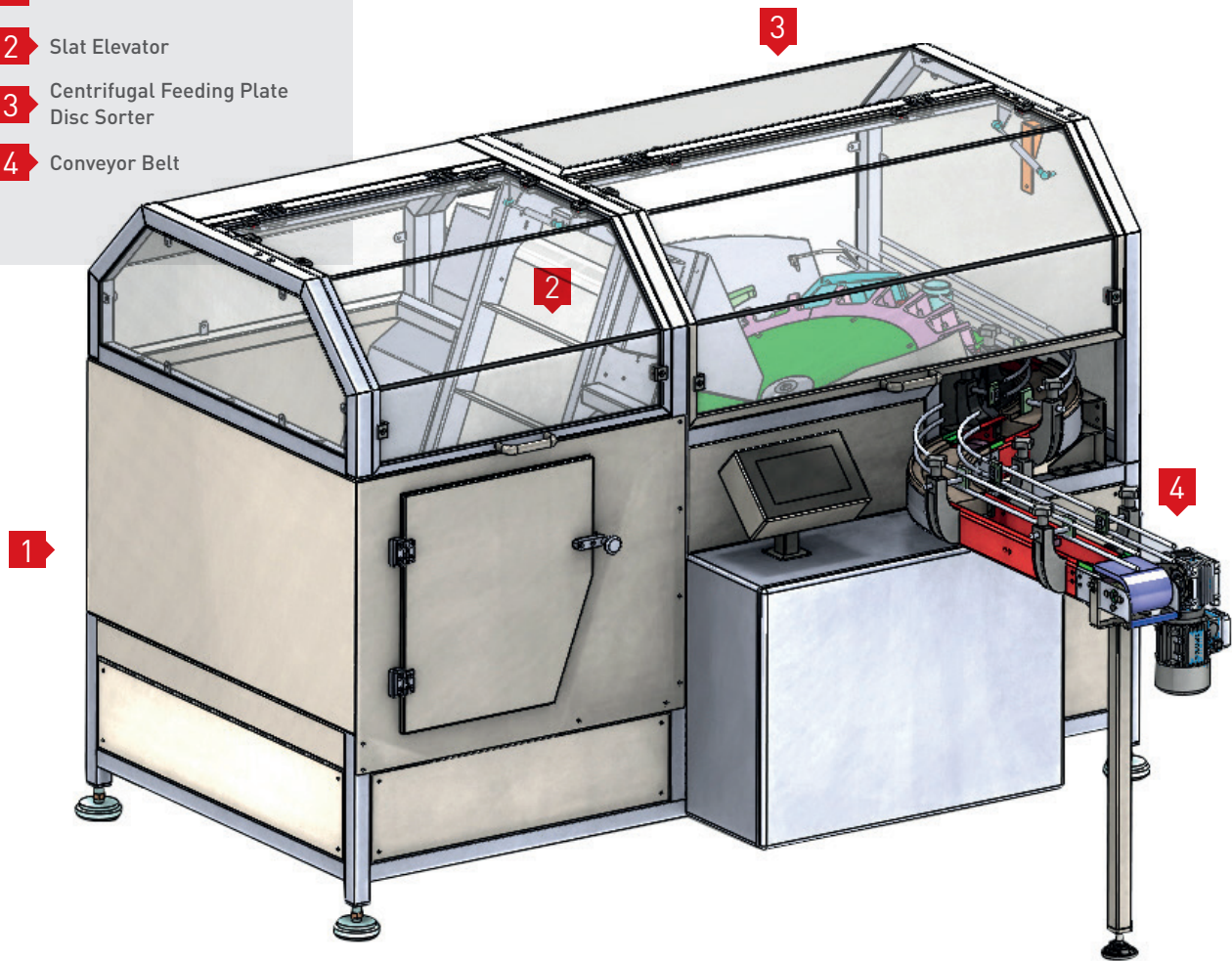

Basic indicative **SA-JF** layout

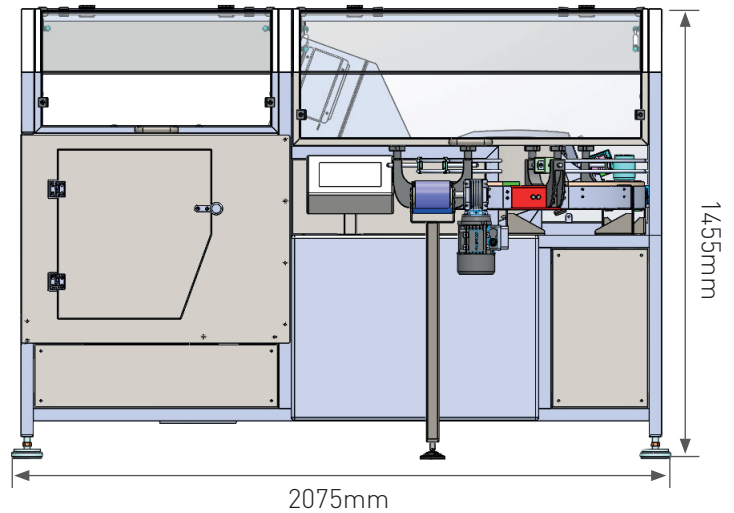
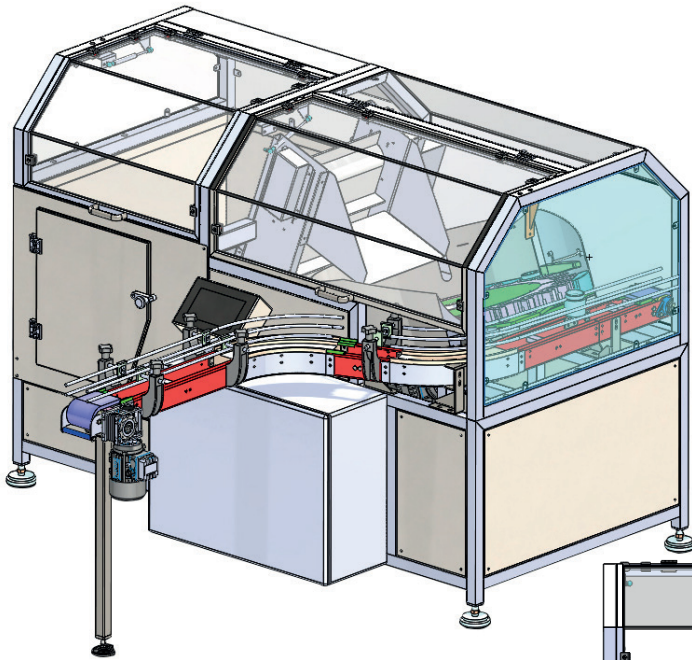

Company overview

Built on over **30 years of tradition and quality**, Shemesh Automation is a family owned and operated business. It has become synonymous with innovation and is home to powerful engineering, design and technology.

The company's expertise is in the development, design and manufacturing of fully automatic packaging, filling, capping, sealing and labelling machines for the cosmetic, pharmaceutical, beauty, biotech, chemical, food and beverage, and nonwovens industries.

Shemesh has its main offices in the US, UK, France and Israel. Its London-based headquarters coordinates global operations and its Israeli office takes advantage of the incredible local engineering talent and innovation. Shemesh's unique combination of UK customer-centric service with an Israeli start-up mentality, to push the technical boundaries, has greatly contributed to its success.



Service & Support

As expert machine designers and integrators we offer a complete end-to-end service. We can supply everything from a single component to a turnkey solution for a full production line.

We deploy our expertise and added value to support our customers around the world as well as to provide a competitive edge.

Shemesh provides a **One-Stop-Shop** which eliminates the costs of dealing with multiple vendors. We provide integral services that cover all aspects of technical support and after sales needs in one contract: reliable, cost-effective, integrated end-to-end solutions.

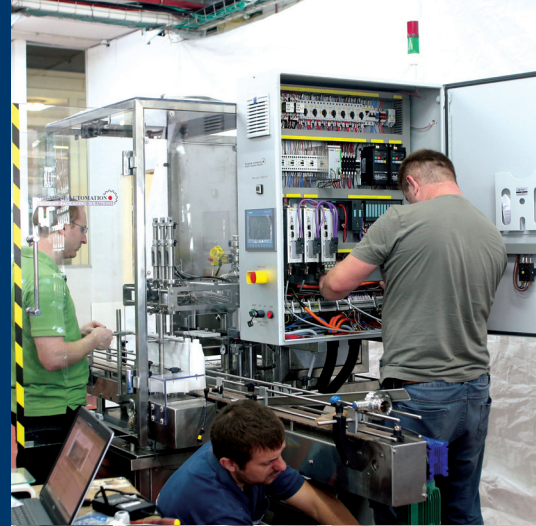

Global presence



Wisconsin, USA

North America HQ

State-of-the-art machine showroom, sales and after-sales support, spare parts inventory and North American logistics centre.

Hampshire, UK

Global Headquarters

CEO's office, Marketing, Strategy, Business Development and Finance.



Semur-en-Auxois, France

European HQ

French team, Tech centre featuring state-of-the-art machinery showroom, sales and after-sales support and European logistics centre.

Tel Aviv, Israel

R&D and Manufacturing

Operations, R&D, Engineering and Manufacturing.



WORLDWIDE

15

International branches

- United Kingdom
- North America
- France
- Latin America
- Israel
- Spain
- United Arab Emirates
- South Africa
- India
- China & Hong Kong
- Japan & Indonesia
- Australia & New Zealand

Over

1800

machines...

CAPACITY

x2

Manufacturing sites

...supported in over

30

countries

6

Trade shows per year

Global representation

Shemesh Automation collaborates with teams on complex Fortune 500 projects and has gained not only a proven and trusted network to put at your disposal, but also invaluable knowledge to help drive your projects.

We share our expertise to guarantee the maximum productivity of your machinery. Our global network of sales representatives and After Sales service specialists offer you flexible and efficient support. Our highly-qualified technicians ensure a fast solution whenever and wherever you need it.

REGIONAL HEADQUARTERS

United Kingdom

Shemesh Automation UK Ltd
Contact: Mr. Carl Gunaratnam

North America

Shemesh USA Inc
Contact: Mr. Jim Livermore

France

Shemesh Automation France
Contact: Ms. Nelly Desbiens

Israel

Shemesh Automation Israel Ltd
Contact: Mr. Luis Coronel

OTHER OFFICES

Spain

Shemesh Spain
Contact: Ms. Leticia Mulet

United Arab Emirates

Shemesh Automation UAE
Contact: Mr. Johann Van Niekerk

South Africa

Shemesh Automation SA
Contact: Mr. Simon Daniels

India

Shemesh Automation India
Contact: Mr. Shilpan Patel

China & Hong Kong

Shemesh Automation Asia
Contact: Mr. Charles Yip

Japan & Indonesia

Shemesh Automation Japan & Indonesia
Contact: Mr. Kentaro Taguchi

Australia & New Zealand

Shemesh Automation Australia
& New Zealand
Contact: Mr. Cameron McKenzie

LATIN AMERICA

Contact: Mr. Nir Baram

GLOBAL SALES

Contact: Mr. Luis Coronel



ATEX



ANTI-CORROSION

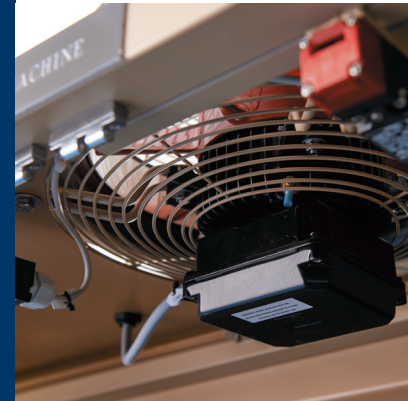

For all sales enquiries please contact us via sales@shemeshautomation.com

Explosion proofed & Corrosion proofed

Corrosive or alcohol-based solutions dictate that your equipment is duly fitted to professionally handle these delicate environments. Years of experience in the field made it possible for us to tailor for you the exact protection so your production is safe and stable while your people and equipment are well protected keeping your facility at the top of the range.

All of our machines are constructed using SST 304/316L, and are available with anti corrosive proprietary coating. As well as the machine base, all vital parts such as nozzles and pumps are also specially treated.



Offices:

United Kingdom

Shemesh Automation UK Ltd
85 Great Portland Street
First Floor
London W1W 7LT
United Kingdom
Tel. +44 758 428 1707



USA

Shemesh USA Inc
1040 Centennial Street
Green Bay
Wisconsin 54304
United States
Tel: +1 920 325 0050



Israel

Shemesh Automation Israel Ltd
4 Ha-Sar Khayim Moshe
Shapira St.
Rishon Lezion 7570406
Israel
Tel. +972 3550 9946



France

Shemesh Automation France
Bopak SARL Building
10 Rue de la Croix Belin
Semur-en-Auxois 21140
France
Tel. +33 (0) 615 210 409



www.shemeshautomation.com



Let us build your vision