



SHEMESH AUTOMATION 
PRUDENT PACKAGING SOLUTIONS

Hemp & Cannabis
Packaging Solutions

World leaders in premium downstream
filling and packaging machinery for the
hemp & cannabis industry



OVER **30** YEARS OF
EXCELLENCE

Let us build your vision

SA Sambax – a universal **monoblock** packaging machine – auto-feed, fill, cap & over-cap with QC for extra small containers and vials. (See page 19)



Hemp & cannabis packaging solutions

Shemesh Automation manufactures premium filling and packaging machinery for pharmaceutical hemp and cannabis products.

With over 30 years' experience, we engineer a complete range of individual and end-to-end systems that make your production faster, smarter and more cost effective.

Our feature-rich products offer strict waste management, minimum downtime, safety, product protection, quality control, operational flexibility and long-term reliability. We do this all under one umbrella leveraging our innovative approach and engineering expertise.

Our solutions include **feeding machines, denesters, unscramblers, labellers, loading machines, filling machines, sealing, capping and labelling solutions**, as well as **case packers** and **palletisers**, all tailored to the cannabis industry.



How it works

Any high-quality packaging line needs top-notch machinery at its core. Shemesh Automation's range of core-line machinery offers innovation at every stage, and reliability you can count on.

Shemesh Automation manufactures premium filling and machinery for both flexible and rigid packaging.

Sample Hemp & CBD **MONOBLOCK** indicative layout

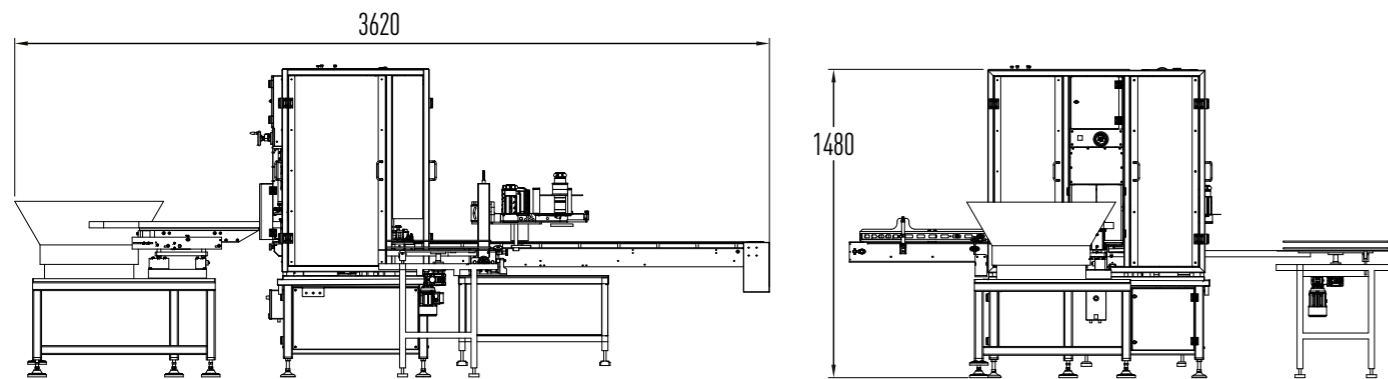

MONOBLOCK configuration: key modules

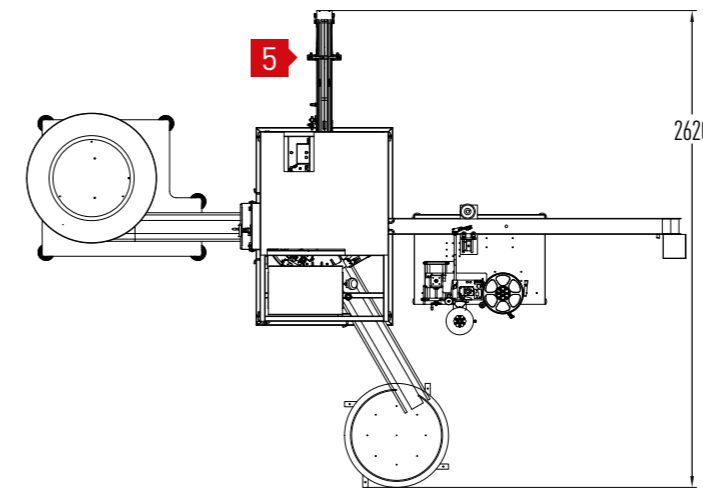
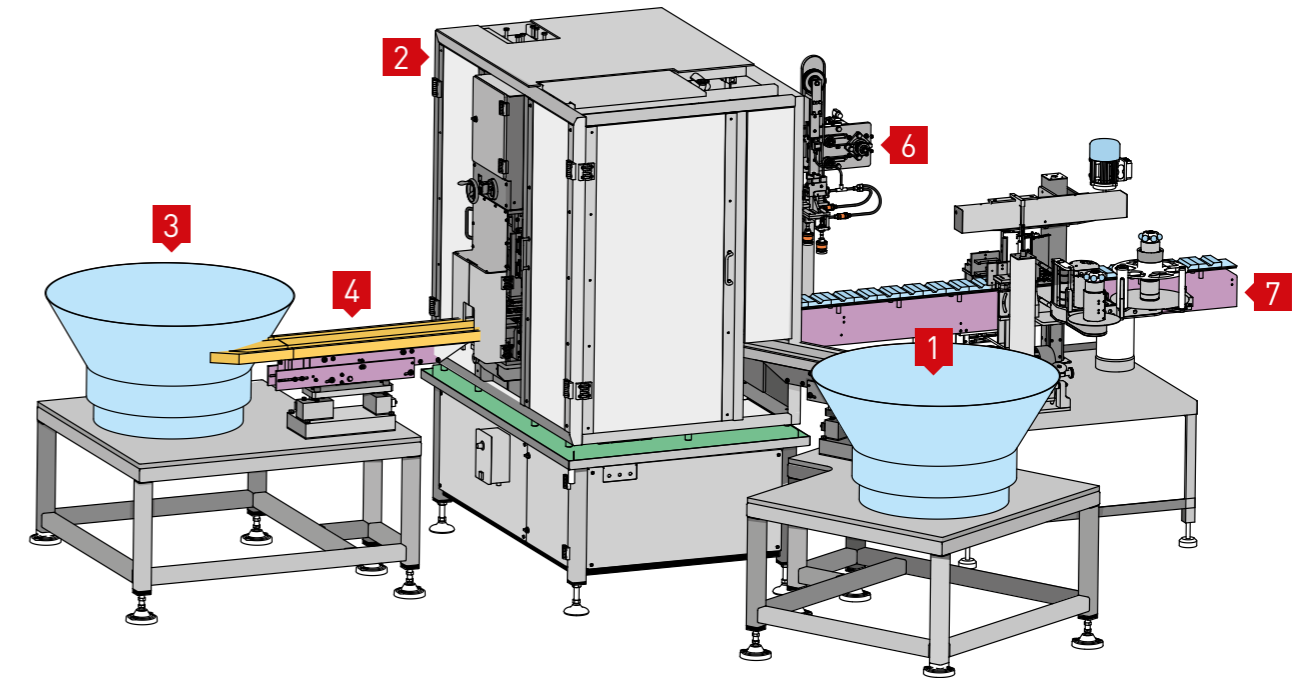

CBD Monoblock Configuration: Key Modules

- 1** Automatic feeder for containers
- 2** Shemesh's **SAMBAX Z** Monoblock – Automatic filling and capping with QC
- 3** Automaticfeeder for caps
- 4** Caps linear vibration feeder
- 5** Rejects conveyor
- 6** Pick and placemanipulator
- 7** Optional: LWA containers labeller

Sample Hemp & CBD **LINEAR** indicative layout

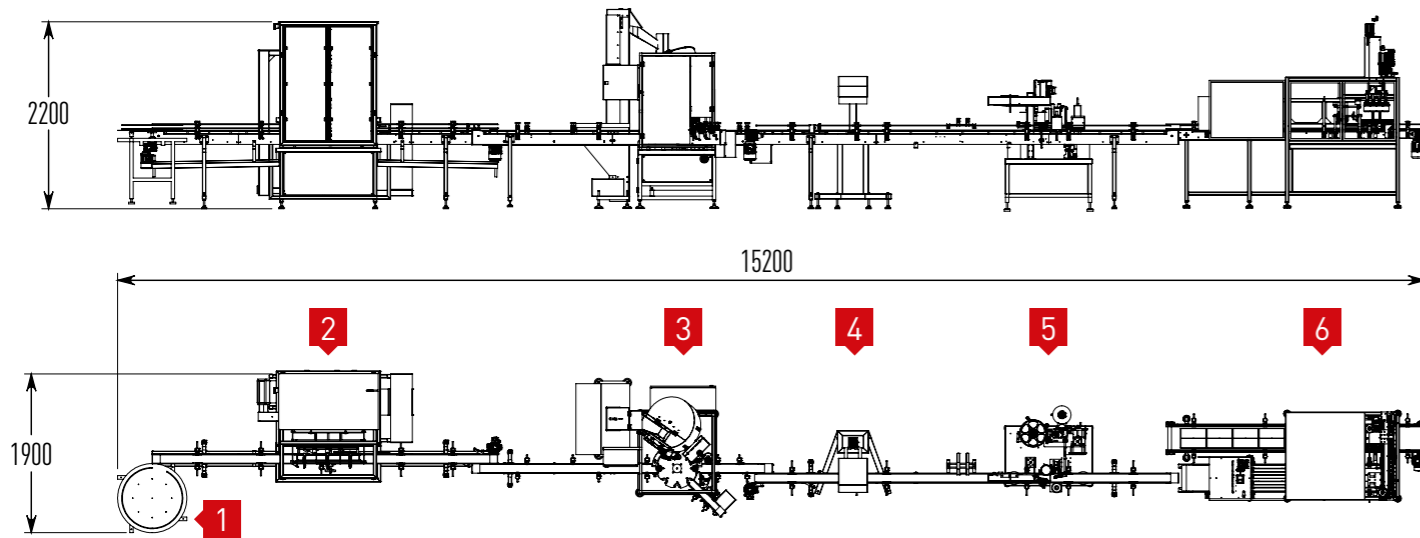

In-Line Modular Configuration: Key Modules

- | | |
|----------------------------------|---------------------------------------|
| 1 In-feed rotary table | 4 Induction unit |
| 2 Filling machine | 5 Labelling machine |
| 3 Thoro – capping machine | 6 Top load case packer machine |

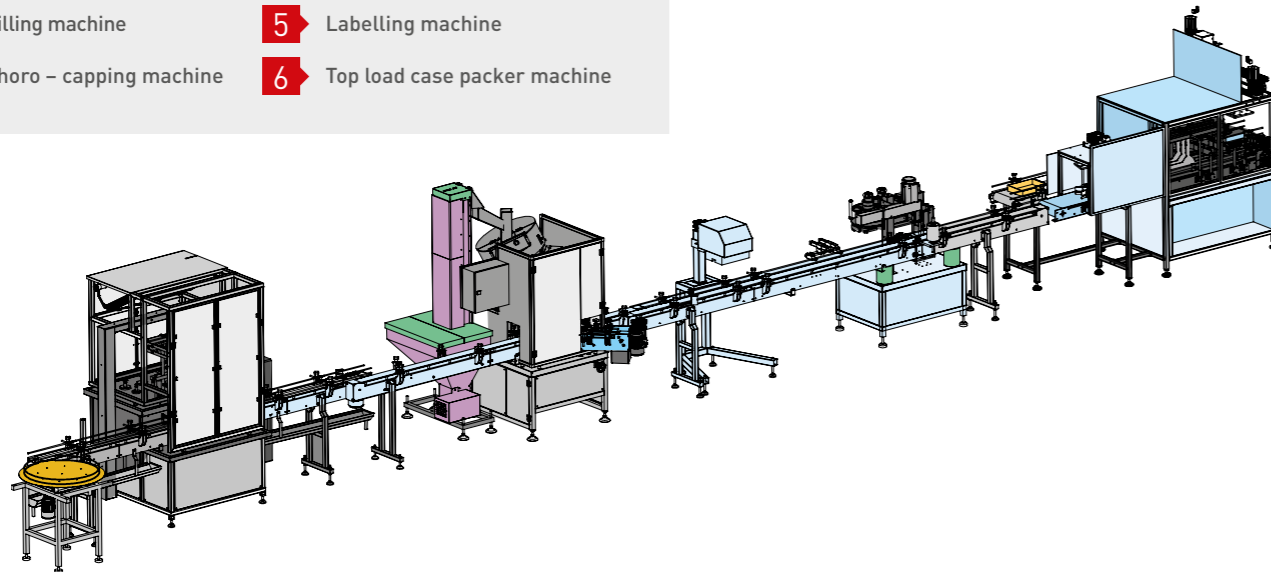

Shemesh Automation portfolio

FEEDING SYSTEMS	8
FILLING SYSTEMS	11
SEALING SYSTEMS	12
CAPPING SYSTEMS	15
LABELLING SYSTEMS	16
ALL-IN-ONE MONOBLOCKS	19
CASE PACKERS & CARTONERS	20
COMBINATORIAL WEIGHERS	20
CBD ACCESSORIES	23



Feeding systems

Feeding Systems – fully-automatic unscramblers, bowl feeders & semi-automatic lazy susan turntables and feeding conveyors.

Unscramblers

SA-CF120 – Fully synchronized CBD containers unscrambler

- Designed to fit various types of **bottles and canisters**
- Existing models throughputs offered in **20-200 units per minute**
- Fully **synchronised** and fully-**automatic**



Bottle Cleaning Systems

EXANE – Automatic inverting air rinsers

- Fully-**automatic**
- Variable speed conveyor & a **sub-15-minute tools-free less changer over**
- Supports both **oval** and **round** containers
- Suitable for **plastic** and **glass** containers
- Speed: **7-8 containers per cycle** and **up to 60 containers per minute**
- Standard air filter with upgrades available
- Throughput model range **20-200 ppm**



EXANE – Automatic inverting air rinsers.



Shemesh STRATUM Servo-driven filling machine.

Filling systems

STRATUM – In-line servo-driven automatic liquid filling machine for viscous and free flowing CBD liquids

- Positive displacement **double servo**-driven piston & diving nozzle filler
- Throughput available from **2 to 12 heads** or **40-180ppm** for up to **500ml** liquid vol
- Suitable for **viscous** and **free** flowing liquids
- Applicable to containers of most common shapes and sizes
- Throughput: **12-16 cycles per minute per filling station** depending on liquid characteristics, for portioning of up to **500ml**
- Available as **automatic** or **semi-automatic**



FGW120 – Positive displacement gear pump linear automatic liquid filling machine

- Throughput model range **20-200ppm**
- Easily adjusted to fill various volumes with **high range of viscosities**
- **Under 20 minutes** tool-less changeover time
- Boasts **proprietary screw-less shower head nozzles** with no drip or overflow
- Supporting **oval, conical, round** and **rectangular canisters**



Sealing systems

SEALPRO – Fully-automatic laminate cutting and thermo sealing machine for CBD products

- **Fully-automatic** laminate cutting and thermo sealing machine with throughputs from **20-200ppm**
- Available in either **in-line** or **monoblock** configurations with fully programmable **seal**, **seal-fill**, or **seal-fill-cap** features



ENERCON – Induction lid sealer

- Pre-cut laminate hermetic induction sealer
- **Seamlessly integrated** to our product portfolio (mechanical, software, electrical)

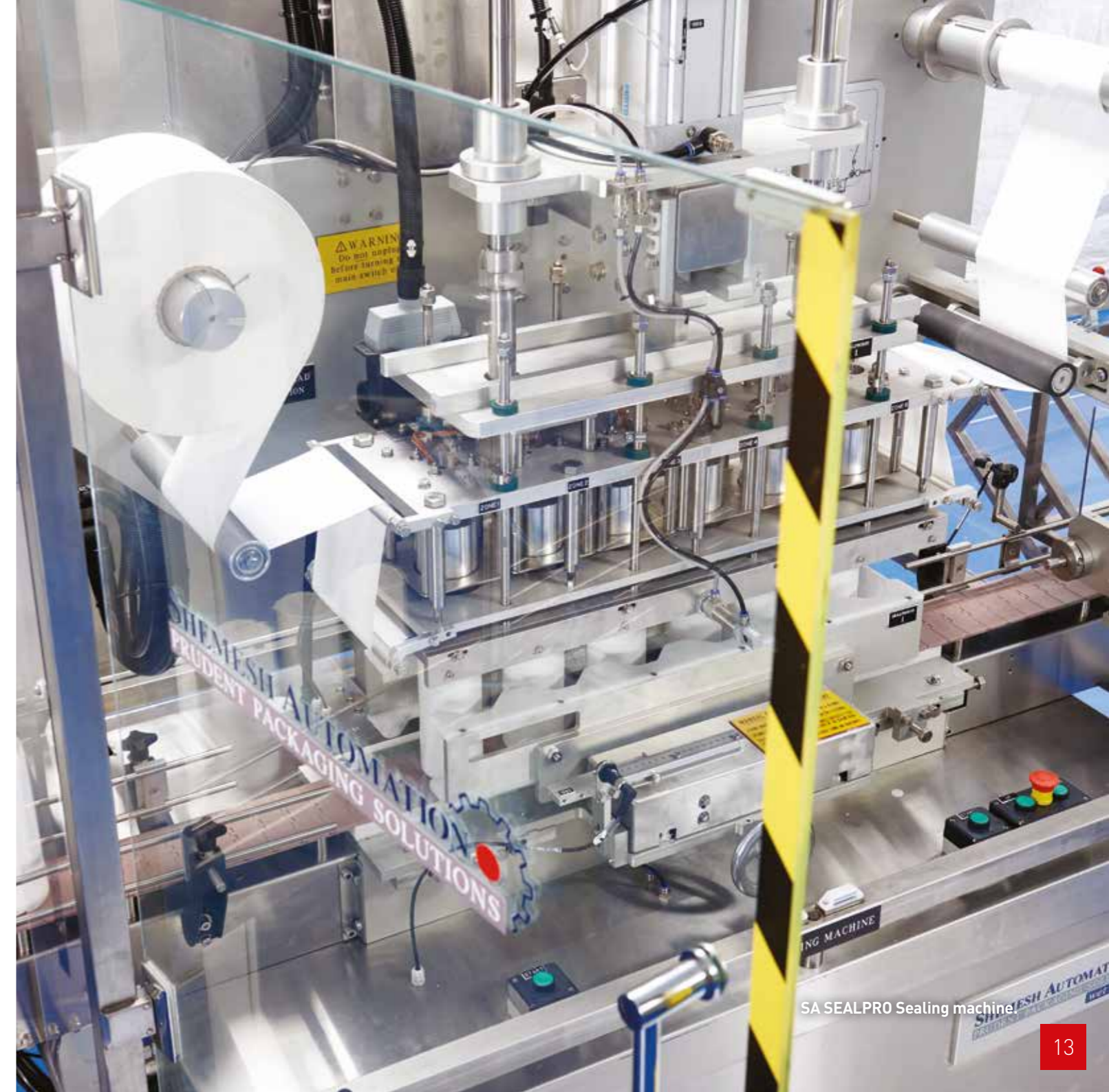

SA SEALPRO Sealing machine



SA THORO Multi container capping machine.

Capping systems

THORO – Screw/twist off/ropp capper for CBD products

- Sanitary servo-driven cam design to provide **super-accurate, leak-free capping**
- Available in both **semi-automatic** and **fully-automatic**
- **60, 120 or 180ppm** models available with either **I, II or III** capping stations
- Wide variety of containers or bottles (eg **plastic, glass** etc)
- Pick & Place method for accurate **screw** or **twist-Off capping**
- Clipping method for accurate **snap-on** and/or **push-pull capping**



VALEXTRA – Advanced snap-on capper

- Complete orientation available to ensure **accurate lid vs container positioning**
- Speeds available in up to **200ppm**
- Lid hopper can contain up to **300ltr/4000 lids** (80mm diameter size)



ALANTRA – Auto air-pump and trigger-nozzle capper

- Trigger and/or spray pump **automatic feeding, orientation & capping**
- Semi-automatic (accommodates up to 2 operators) or fully-automatic (for hands-free operation) models available
- Throughput: **60 containers/min** or **up to 120 containers/min** (double station)
- **Sanitary design**
- Handles wide variety of containers, bottles and shapes (eg **plastic, glass, round, square, cylindrical, conical**, etc)
- Pick & Place method for **accurate capping**
- Digital, servo-driven adjustable torque for **flexibility** and **precision**
- Universal proprietary gripper fits both **spray** and **trigger** caps. No tools, no downtime required



Labelling systems

Labelling Systems – front and back, wraparound, top and bottom and tamper evident labelling, applicable to all CBD containers types and shapes.

LWA Labelling series

- LWA Front and Back labelling to **flat panels** or **oval containers**
- LWA Wraparound labelling to **cylindrical** and **conical containers**
- LWA Universal Labelling: Front and/or back application of labels to **flat panels, ovals or cylindrical containers** coupled with a **wraparound labelling** feature for **cylindrical** and/or **conical containers** as well as **top and bottom labelling** as required



AREVA – High end labeller and tray filler for CBD vials and small round bottles

- Offers **front and back labelling, partial or full wraparound** with orientation unit
- **Quick** and **easy changeover** time
- Fully **hands-free labelling** machine designed specifically for **vials** and **small round bottles**
- Different model speeds offered from **20-200ppm**
- **Full QC, printing** and **coding** features available including a **defects rejection** unit



SA LWA Labelling machine.



SA SAMBAX-Z for CBD vials & extra small containers monoblock.

Monoblock **systems**

SAMBAX SERIES – Auto feed, fill, cap & over-cap with QC for small & extra-small containers and vials for CBD products

- **SAMBAX** model for medium containers and vials ranging from **350ml** to **5ltr**
- **SAMBAX-Z** model for small and extra small containers and vials ranging from **5ml** to **350ml**
- Western European **pharma-grade** machine build standard
- Fully-automatic **feed, fill, pick & place cap** and **over-cap** with **QC**
- **Thermal** or **induction** seal, caps or nozzles 'insertions' as well as labelling & coding available as an option
- Models throughput range from **20ppm** up to **100ppm**



MULTI 1 – Horizontal FFS with integrated stacker, packer & product auto feeder for the creation of flat sachets suitable as samples or product promotions

- **Servo-driven** cam design
- Fully-automatic feed to **form, fill, seal, cut, stack** and **carton pack** sachets with complete QC
- Coding and printing via an internally integrated, easily accessible **Markem Imaje printer**
- Pre-cut perforation
- **Auto-stacking** and **packing** of sachets into boxes



Case packers & cartoners

Case Packers & Cartoners

RELENTLESS – End-of-line case form, fill and seal

- Throughput: up to **15 cases per minute** (SILVERLINE) / up to **25 cases per minute** (SXS)
- Ability to handle **multiple product types** and **carton configurations**. Servo motor driven container manipulator
- **Quick changeover** time
- Designed for **minimum space** requirements
- Versatile configuration with an ability to use all or just part of the functions offered
- No need to stop for magazine charging



Combinatorial Weighers

MULTI HEAD WEIGHER – For cannabis flowers

- Suitable for weighing customer's products where each piece measures **approx. 1"x1"x1"**
- Weight of the mixing can be **automatically** compensated by the last products
- Affords **high accuracy** and tailored load cell
- Includes a **high-speed stagger dump** function and new Modular and CAN bus technology
- Highly **efficient** and **stable** outputs



SA RELENTLESS Case packer.

Accessories

In addition to the core, front and end-of-line equipment shown here, Shemesh Automation also specialises in providing the following accessories and services:

- Conveyors
- Weight checkers
- Metal detectors
- Coding systems
- Printing systems
- QC systems
- Complete integration services
- Project planning
- Consultation services

SA SAMBAX-Z for CBD vials & extra small containers monoblock.



Service & support

Shemesh Automation Support has a global network of sales representatives and After Sales service specialists to offer you flexible and efficient support. Shemesh Automation Support shares our knowledge to guarantee the maximum productivity of your machinery and our worldwide service network of qualified technicians ensures a fast solution whenever and wherever you need it.

Shemesh Automation Support deploys our expertise and leading-edge technology to support our customers, providing them with added value as well as the necessary competitive edge to advance in global markets. As expert machine designers and system integrators we offer a complete end-to-end service. We can supply everything from a single component to a turnkey solution for a full production line.

Shemesh Automation Support also provides integral services that cover all aspects of technical support and after sales needs in one contract: Reliable, cost effective, integrated end-to-end solutions.

The one-stop-shop advantage

The 'one umbrella' advantage eliminates questions of responsibility and minimises the costs involved in dealing with multiple vendors. The open relationship this creates can result in greater expertise, enhanced efficiency, lower costs and improved product quality.

This in turn leads to increased market share opportunities and higher overall profit margins for our customers.

Adding value to our clients

Partnering with Shemesh Automation, our customers don't simply get a machine, but engage in a meaningful, long-term relationship through which they can build their business on our experience, knowledge, reliability and most importantly, integrity. Our clients know that we are right behind them, everywhere, always. After all, their success is ours too, pure and simple.



Company overview

Built on over 30 years of tradition and quality, Shemesh Automation has become synonymous with innovation and is home to powerful engineering, design and technology.

Experts in the development, design and manufacturing of fully-automatic packaging, filling, capping, sealing and labelling machines for the cosmetic, pharmaceutical, beauty-care, biotech, nonwovens, chemical, and food and beverage industries, Shemesh is proud to have over **1800 machines** in operation worldwide. Our unique offering includes a full range of solutions, as well as full application, global support and customer service.

Our Israeli R&D and manufacturing operations tap into the renowned expertise of the local engineering talent and provide the most competitive technologies to our customers. This coupled with our continuous investment in state-of-the-art technology means we remain at the leading edge of the automation industry. Innovation is at the heart of everything we do; it is our obsession!

We are strategically placed across the globe in the UK, Israel, France and the USA, as well as sales and support teams in Europe, the Americas and the Far East. Our UK-based office coordinates all our global operations.

Our efficient sales teams support our clients in choosing custom solutions to match any requirement. Whether it is a single machine, monoblock or a complete turnkey production line, everything we do is tailored to the specific needs of the customers and their industries.

Partnering with Shemesh Automation, our customers don't simply get a machine, but the support, experience, knowledge, reliability and integrity of a company who are at the forefront of automation. **"Let Us Build Your Vision"** is not just our slogan, rather this is what we ultimately do day-in, day-out!

Contact our team of experts for free advice today!

www.shemeshautomation.com

sa@shemeshautomation.com



"As a long standing Shemesh Automation customer we knew we were in good hands when decided to buy their new MULTI1

machine. What we did not know is our expectations would be completely exceeded during this project – in the most positive manner. Not only were communications very well managed across multi-cultural, cross-global teams with the Shemesh team available around the clock – but the Multi1 itself would ultimately pleasantly surprise us with its accuracy, production consistency, attention to the smallest details and staggering simplicity – all of which are truly overwhelming."

Zvi Nachum,
Lead Medical Equipment Development Engineer,
I-Med Pharma

Offices:

United Kingdom

Shemesh Automation UK Ltd
85 Great Portland Street
First Floor
London W1W 7LT
United Kingdom
Tel. +44 758 428 1707



USA

Shemesh USA Inc
1040 Centennial Street
Green Bay
Wisconsin 54304
United States
Tel: +1 920 325 0050



Israel

Shemesh Automation Israel Ltd
4 Ha-Sar Khayim Moshe
Shapira St.
Rishon Lezion 7570406
Israel
Tel. +972 3550 9946



France

Shemesh Automation France
Bopak SARL Building
10 Rue de la Croix Belin
Semur-en-Auxois 21140
France
Tel. +33 6 15 21 04 09



www.shemeshautomation.com



Let us build your vision