

SHEMESH AUTOMATION
PRUDENT PACKAGING SOLUTIONS

SAMBAX SERIES



Truly universal Monoblock packaging machines for medium, small and extra-small containers and vials.

- Applicable to containers and vials of most common shapes in the pharmaceutical and cosmetics industries
- Auto Feed, Fill, Seal, Cap & Over-cap with Labelling and QC
- Single and double-lane systems available for speeds of up to 100ppm
- Sambax-Z model available for extra-small containers and vials



Let us build your vision



The **SAMBAX Series**' all-in-one monoblock design meticulously encompasses all aspects of your core production needs, from containers multifeeding, double servo-driven viscose filling, capping, over capping, sealing, labeling, discharging and QC.

SAMBAX SERIES

With dedicated models for almost every common type of medium (**SAMBAX**), small and extra-small (**SAMBAX-Z**)

containers and vials, the **SAMBAX Series** is your all-in-one pharmaceutical and cosmetics production unit.



Quick fact sheet

SAMBAX and SAMBAX-Z

- **SAMBAX** model for medium containers and vials ranging from **350ml to 5 Litres**
- **SAMBAX-Z** model for small and extra small containers and vials ranging from **350ml to 5ml**.
- **Western European Pharma grade machine build standard**
- Fully-automatic feed, fill, pick & place cap and overcap with QC. Thermal or induction seal, caps or nozzles "insertions" as well as labelling & coding available as an option
- Models throughput range from **20ppm up to 100ppm**.
- **Festo (Germany) Double Servo** Filling technology both in the pistons and the **diving nozzles** for production consistency and a **staggering +/-0.25% of liquid volume accuracy**
- **INDUSTRY 4.0 READY:** SECOMA Site Manager 1139 modem, integrated into the machine HMI to enable SMART remote support, live stats and performance analysis as well as manufacturer enhancement feedback
- Entire machine is **Stainless Steel 316L**.
- Stainless steel, no-screws sanitary welding for all liquid pipes. Liquid smart filling tank made of 316L stainless steel, with electro polish finishing.
- All flexible piping is **FDA approved**. No screws in nozzles. Tri-clamp connections.
- Built in CIP. (Clean in place). Built in **Spray balls** for **enhanced CIP**
- Round, hermetically-sealed tank design. "Double-jacket" heated tank, built in agitators - an option
- Up to 20 programmed product recipes
- Doors and top cover made of Lexan or Polycarbonate.
- **Sub 1% machine defect rate**
- Cost effective, time efficient Line maintenance, cleaning and changeover. Filling auto flushing mode available for up to 95°C (203°F) hot liquid

STANDARD SPECS

- **Industry 4.0**-ready
- **Festo (Germany) pneumatics and Servo systems**
- Complete **SST304/316L** design
- **FDA** approved piping as applicable
- **SIEMENS (Germany) PLC & HMI** and **MOTORS**
- **BANNER** sensors
- **E-stop** buttons and safety interlocks wired through **CAT IV** safety controller.
- **CE Marking**

For a full demo of the SAMBAX in action please visit us at www.shemeshautomation.com

HEMESH AUTOMATION
RUDENT PACKAGING SOLUTIONS



The **SAMBAX** Series is the latest in a series of bestselling Monoblocks from Shemesh Automation, building on the success of the **CITADEL** and **XPANDER** Series'.

Photo: Shemesh Automation SAMBAX- monoblock auto feed, fill, cap and over cap for vials.



“Strict waste management, minimum downtime and space design, safety, product protection, operational flexibility and long-term reliability are in the core DNA of our product portfolio and engineering mindset.”

Nir Baram, Vice President LATAM Sales,
Global After Sales & P.M. Shemesh Automation





The **SAMBAX** series is available with a **Double-Servo** Filling upgrade for enhanced production consistency and accuracy featuring fully synchronised **Festo (Germany)** servo-driven pistons and servo-driven **diving nozzles**.



A fully-integrated, Shemesh-made, automatic **STRATUM** filler & **THORO** capper basic line for strawberry sauce. More advanced automation can also include automatic feeders, sealers, advanced QC, case packing and more – all under ONE umbrella and made by Shemesh.

Basic indicative **SAMBAX Series** layout

Generic SAMBAX Layout

- 1 Automatic Feeder for containers
- 2 SA SAMBAX Z Monoblock - Automatic Filling and Capping with QC
- 3 Automatic Feeder for Caps
- 4 Caps Linear Vibration Feeder
- 5 Rejects Conveyor
- 6 Pick and Place Manipulator
- 7 Optional: LWA Containers labeller

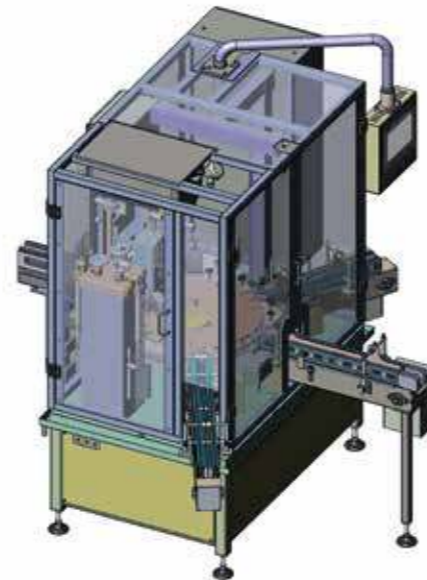
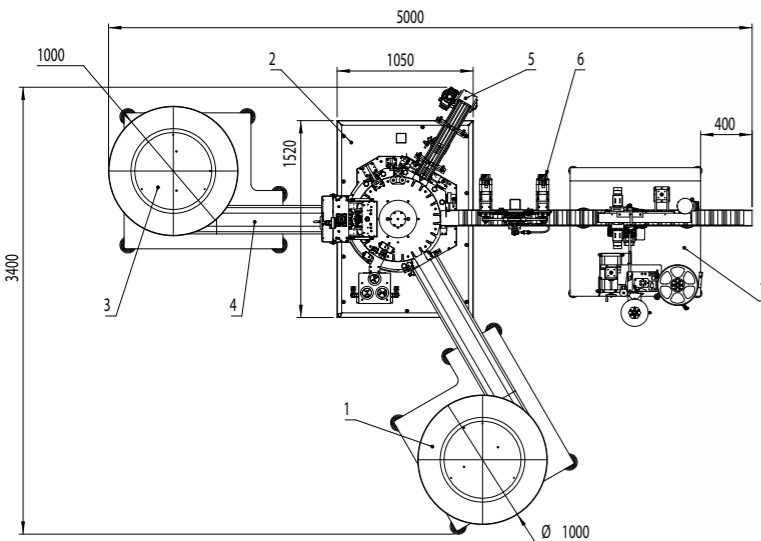
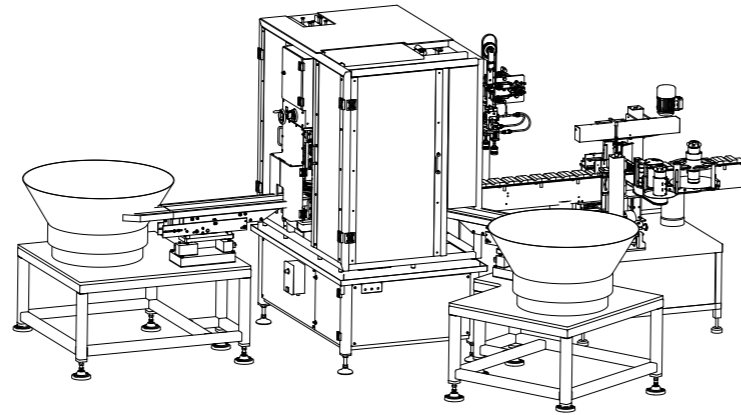

"As the leading brand in sanitization and hygiene products, an impeccably clean packaging process is imperative. Also, in such a competitive market, achieving maximum process efficiency is crucial to maintaining our competitive edge. We were so thrilled at how Shemesh's Sambax-Z monoblock achieved both of the above that we did not hesitate to return to Shemesh a year later when we needed a complete sanitisers filling line. Their machines, service, and industry knowledge really are second to none".

Ron Hoffman, Director of Operations, Durisan, USA

Global presence



Wisconsin, USA
North America HQ

State-of-the-art machine showroom, sales and after-sales support, spare parts inventory and North American logistics centre.

Hampshire, UK
Global Headquarters

CEO's office, Marketing, Strategy, Business Development and Finance.



Semur-en-Auxois, France
European HQ

French team, Tech centre featuring state-of-the-art machinery showroom, sales and after-sales support and European logistics centre.

Tel Aviv, Israel
R&D and Manufacturing

Operations, R&D, Engineering and Manufacturing.



WORLDWIDE

15

International branches

United Kingdom
North America
France
Latin America
Israel
Spain
United Arab Emirates
South Africa
India
China & Hong Kong
Japan & Indonesia
Australia & New Zealand

Over

1800

machines...

CAPACITY

x2

Manufacturing sites

...supported in over

30

countries

6

Trade shows per year

Global representation

Shemesh Automation collaborates with teams on complex Fortune 500 projects and has gained not only a proven and trusted network to put at your disposal, but also invaluable knowledge to help drive your projects.

We share our expertise to guarantee the maximum productivity of your machinery. Our global network of sales representatives and After Sales service specialists offer you flexible and efficient support. Our highly-qualified technicians ensure a fast solution whenever and wherever you need it.

REGIONAL HEADQUARTERS

United Kingdom
Shemesh Automation UK Ltd
Contact: Mr. Andrew Hayward

North America Shemesh USA Inc
Contact: Mr. Jim Livermore

France Shemesh Automation
France Contact: Ms. Nelly
Desbiens

Israel Shemesh Automation Israel
Ltd Contact: Mr. Luis Coronel

OTHER OFFICES

Spain
Shemesh Spain Contact: Mr.
Joaquim Julve

United Arab Emirates Shemesh
Automation UAE Contact: Mr.
Johann Van Niekerk

South Africa

Shemesh Automation SA
Contact: Mr. Simon Daniels

India

Shemesh Automation India
Contact: Mr. Shilpan Patel

China & Hong Kong

Shemesh Automation Asia
Contact: Mr. Charles Yip

Japan & Indonesia

Shemesh Automation Japan & Indonesia
Contact: Mr. Kentaro Taguchi

Australia & New Zealand

Shemesh Automation Australia
& New Zealand
Contact: Mr. Cameron McKenzie

LATIN AMERICA

Contact: Mr. Nir Baram

GLOBAL SALES Contact: Mr Luis
Coronel



Explosion Proofed & Corrosion Proofed

Corrosive or alcohol-based solutions dictate that your equipment is duly fitted to professionally handle these delicate environments. Years of experience in the field made it possible for us to tailor you the exact protection so your production is safe and stable while your people and equipment are well protected keeping your facility at the top of the range.

All of our machines are constructed using SST 304/316L, and are available with anti corrosive proprietary coating. As well as the machine base, all vital parts such as nozzles and pumps are also specially treated.



SHEMESH AUTOMATION'S
FGW-120 FILLING MACHINE WITH
COMPLETE EXPLOSION (EX) AND
CORROSION PROTECTION

For all sales enquiries please contact us via sales@shemeshautomation.com

Offices:

United Kingdom

Shemesh Automation UK Ltd
85 Great Portland Street
First Floor
London W1W 7LT
United Kingdom
Tel: +44 758 428 1707



USA

Shemesh USA Inc
1040 Centennial Street
Green Bay
Wisconsin 54304
United States
Tel: +1 920 325 0050



Israel

Shemesh Automation Israel Ltd
4 Ha-Sar Khayim Moshe
Shapira St.
Rishon Lezion 7570406
Israel
Tel. +972 3550 9946



France

Shemesh Automation
France Bopak SARL Building
10 Rue de la Croix
Belin Semur-en-Auxois 2
1140
France
Tel. +33 6 15 21 04 09



www.shemeshautomation.com



Let us build your vision