

**SHEMESH AUTOMATION**  
PRUDENT PACKAGING SOLUTIONS

# ENCORE



State-of-the-art complete monoblock packer with throughputs of 30ppm or 60ppm for liquids and solids in doypacks.

- Fully automated
- Doypack feed
- Auger filling for powders, granules or solids
- Liquid filling
- Doypack sealing, cooling and eject
- All in one block with full QC!



*Let us build your vision*

# ENCORE

from Shemesh Automation:

A complete, state-of-the-art, precision-designed, single-block packaging machine for liquid and solids in Doypacks.





# ENCORE

From foodstuffs and beverages, to chemicals, detergents, cosmetics and pharmaceuticals, **ENCORE** is a revolutionary one-stop-shop monoblock for all of your Doypack packaging needs.

Shemesh Automation's **INDUSTRY 4.0 READY ENCORE** Monoblock automatically feeds, auger fills, liquid fills, seals and QC's Doypacks at speeds of up to 30ppm or 60ppm, depending on the model.



# ENCORE

## The 12-Station Servo-Driven Index Table

- 1 Bags Inlet
- 2 Bags Opening
- 3 Bag Inflation
- 4 Auger Filling
- 5 First Step Liquid Filling
- 6 Second Step Liquid Filling
- 7 Bag Sealing
- 8 Bag discharging, cooling and QC
- 9 Bags Magazine
- 10 Smart Liquid Tank

## Bag sizes supported by the ENCORE<sup>®</sup>:

	Min. Width	Max. Width	Min. Height	Max. Height
Bag	140mm	300mm	200mm	350mm
Jumbo	280mm	500mm	250mm	550mm

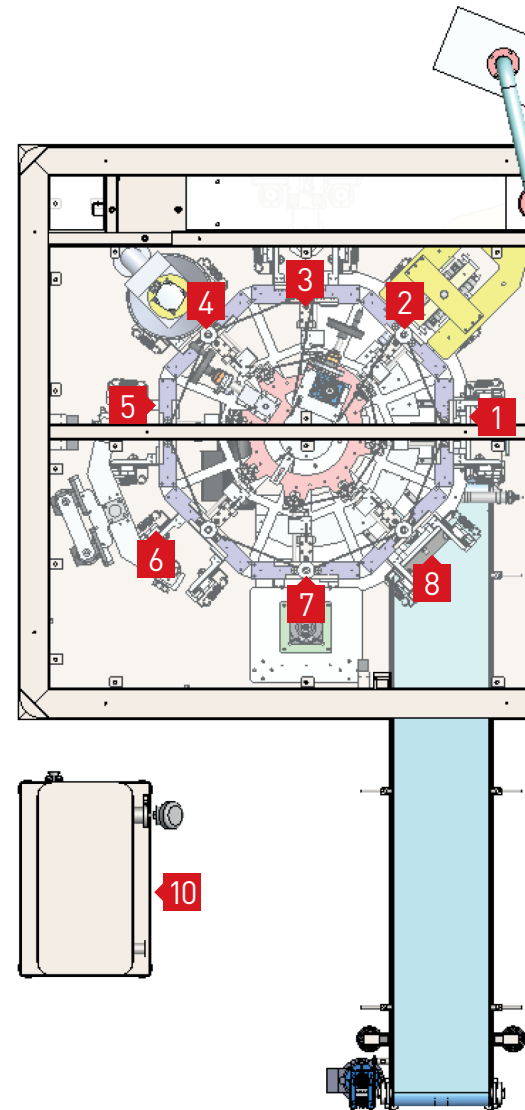



# How it **works**

With operating speeds of up to 30ppm or 60ppm, depending on the model, the **ENCORE** is a robust, fully-automatic, servo-driven vertical indexer monoblock. It is specifically designed as a single block for the downstream packaging of solid, granules or powders together with or without liquid products in Doypacks.

Representing state-of-the-art packaging technology and specs, the **ENCORE** functions as a hands-free turnkey unit and is designed as a space sensitive machine.

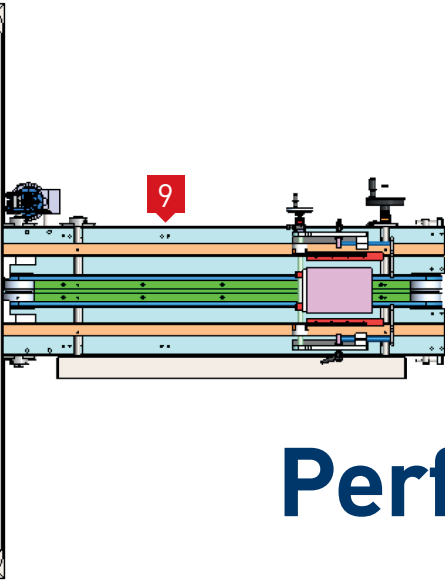

## Perfect for



POUCH WITH  
SIDE CAP



POUCH WITH  
TOP CAP



SHAPED  
POUCH



SHAPED POUCH  
WITH TOP CAP



STRAIGHT  
POUCH

Shemesh Automation's unique **ENCORE** monoblock is offered as an "R" model for the regular doypacks market as well as a "J" model for the jumbo Doypacks.

# ENCORE

## Features



The **ENCORE** possesses a number of specially designed features to support easy and reliable operation:

- Throughput of up to **30ppm/60ppm** (regular size), **12-15** (jumbo size)
- **INDUSTRY 4.0 READY**: SECOMA Site Manager **1139 modem**, integrated into the machine HMI to enable **SMART** remote support, live stats and performance analysis as well as manufacturer enhancement feedback.
- All welded to pharma sanitary standards using **316L stainless steel** and constructed using **USDA/ FDA approved** materials
- Proprietary design for operational flexibility and ultra low, tools free **sub 30 minutes** format parts changeover downtime
- **Advanced QC**
- Enhanced, height-adjustable anti-overflow, proprietary designed filler nozzles. Portioning tolerance of **0.5% of filling volume** – reducing waste
- **Closed bags** opening feature
- Bag inflation: bags are inflated with the exact amount of air needed to facilitate **speedy opening** and **filling**.

- **Two-stage filling** for liquid, minimising foaming and spillover whilst achieving a higher throughput
- **Auger filling** for solids and powders
- Easy-to-access '**smart**' controls with multiple HMI's around the **ENCORE** for simple operation
- **Air evacuation**

### STANDARD SPEC

- **Industry 4.0**-ready
- **FESTO (Germany)** Servo drivers, pistons and motors
- Complete **SST304/316L** design
- **FDA** approved piping as applicable
- **SIEMENS (Germany)** PLC & HMI and MOTORS
- **BANNER** sensors
- **E-stop** buttons and safety interlocks wired through **CAT IV** safety controller.
- **CE Marking**

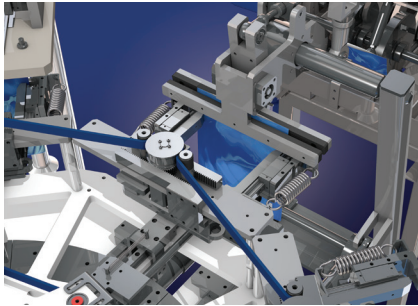

### STATION 1: DOYPACK AUTOMATIC FEEDING FROM THE ENCORE MAGAZINE

Doypack magazine is loaded manually. Doypack loading device pulls Doypacks out of the magazine and loads them into the carousel in a vertical position. A set of two top grippers transfers the DOYPACK into the next station.

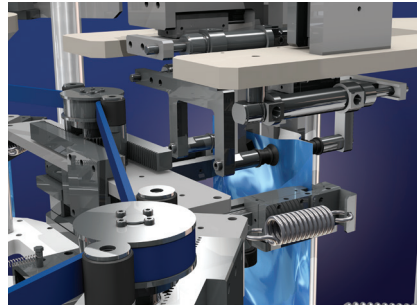

### STATION 2: DOYPACK OPENING

The Doypacks are then positioned beneath a set of pincer arms for initial opening. A piston-controlled conic pouch opener then moves down, into the Doypack and begins opening it.

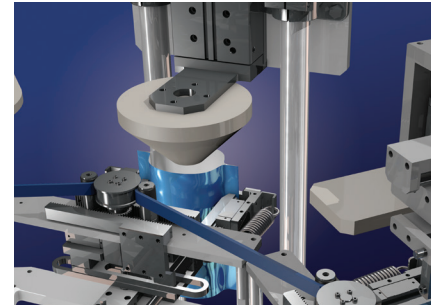

### STATION 3: DOYPACK INFLATION

The Doypacks are inflated with the exact amount of air needed to complete the opening procedure and in order to facilitate the Doypack filling.



“Looking at the **ENCORE**, and the attention to detail with which its meticulous mechanics were designed, I can proudly say the SA team has once again successfully identified an unanswered client need and brought a winning product to market. To achieve this, we truly leveraged on our vast existing know-how, great experience and constant client interactions.”

**Shai Shemesh**, President.



The **ENCORE** has a built-in QC & reject system, Siemens HMI & PLC, is Industry 4.0 ready, made of SST316L, is servo-driven and delivers under 1% defect rate.

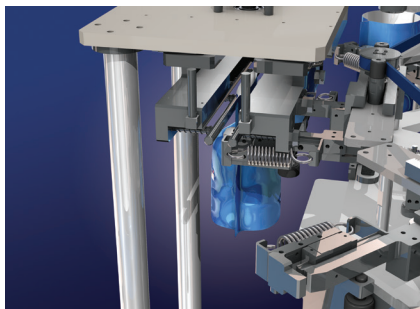
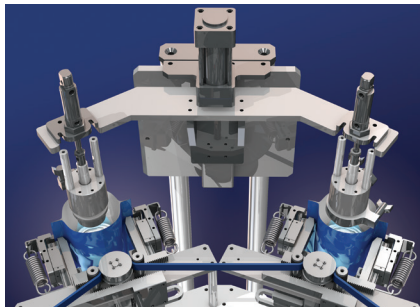

#### **STATION 4: AUGER FILLING**

Accurate, programmable filling of solids, granules, or powders. Combinatorial weight filling available.

#### **STATION 5 AND 6: TWO-STEP DOYPACK LIQUID FILLING**

Encore employs two-station filling to avoid foaming and spillover, using encoder-equipped nozzles and gear pumps or other methods as needed according to the product. Shemesh Automation's anti overflow, proprietary designed, sanitary, screwless shower nozzles spray the required pre-set amount of liquid equally into each Doypack. Pumps filling speed may be adjusted through the touch screen. Filling capacity range from 50cc to 5000cc of liquid.

#### **STATION 7: AIR EVACUATION & DOYPACK SEALING**

The Doypacks are positioned between the top sealing applicator clamps where a Sealing Applicator presses the top edges together until they are properly sealed. The air evacuation system ensures the required amount of air is sucked out of the bag before sealing.

#### **STATION 8: DOYPACK COOLING, DISCHARGING AND QC**

Doypacks are led into the cooling and discharging zone. The Encore's cooling device grabs each Doypack for the optimal cooling time depending on the particular material. The product is then passed through a checkweighing system which rejects any irregular product via a discharge conveyor.

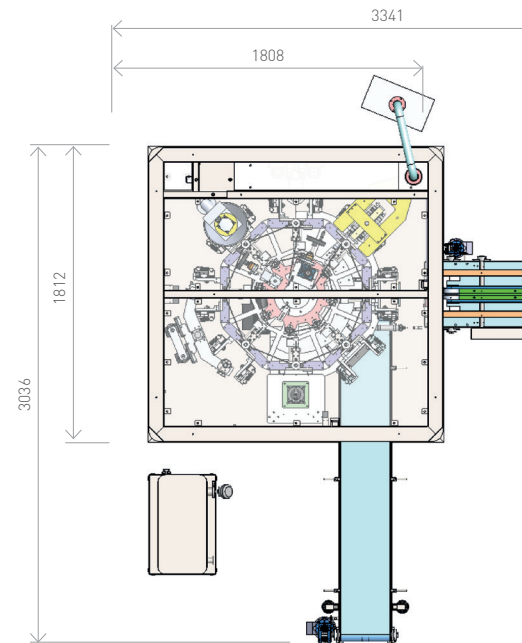

# How the **ENCORE** measures up

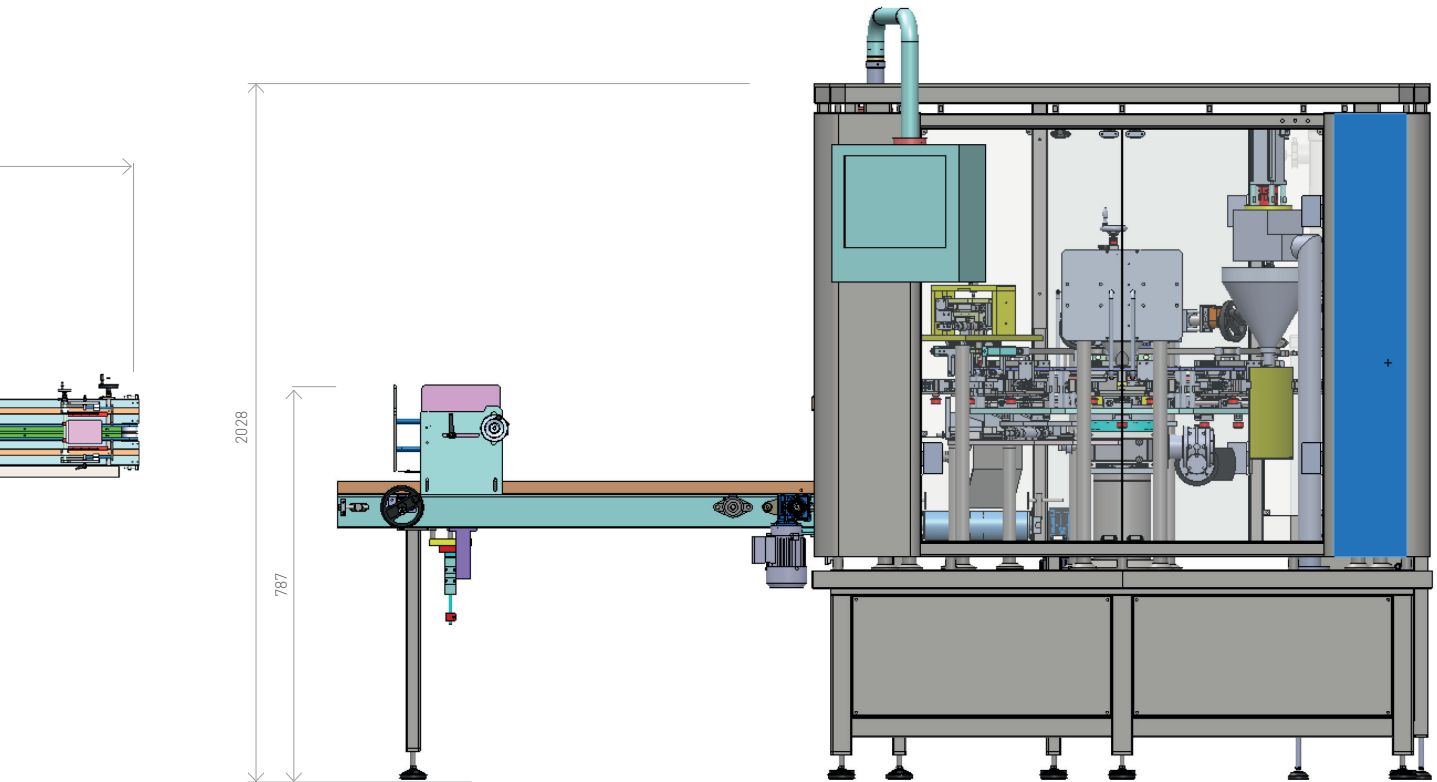

# Global presence



**Wisconsin, USA**  
North America HQ

State-of-the-art machine showroom, sales and after-sales support, spare parts inventory and North American logistics centre.



**Semur-en-Auxois, France**  
European HQ

French team, Tech centre featuring state-of-the-art machinery showroom, sales and after-sales support and European logistics centre.





**Hampshire, UK**  
Global Headquarters

CEO's office, Marketing,  
Strategy, Business  
Development and Finance.



**Tel Aviv, Israel**  
R&D and Manufacturing

Operations, R&D,  
Engineering and  
Manufacturing.



**WORLDWIDE**

**15**

International branches

United Kingdom  
North America  
France  
Latin America  
Israel  
Spain  
United Arab Emirates  
South Africa  
India  
China & Hong Kong  
Japan & Indonesia  
Australia & New Zealand

Over

**1800**

**machines...**

**CAPACITY**

**x2**

Manufacturing sites

...supported in over

**30**

**countries**

**6**

Trade  
shows  
per year





“Shemesh Automation works closely with its customers to unlock maximum productivity, operational flexibility, long-term reliability, safety and efficiency. This, coupled with world-class engineering and out-of-the-box mindset, is key to everything we do.”

**Nir Baram**, V.P. Global Sales & Business Development.

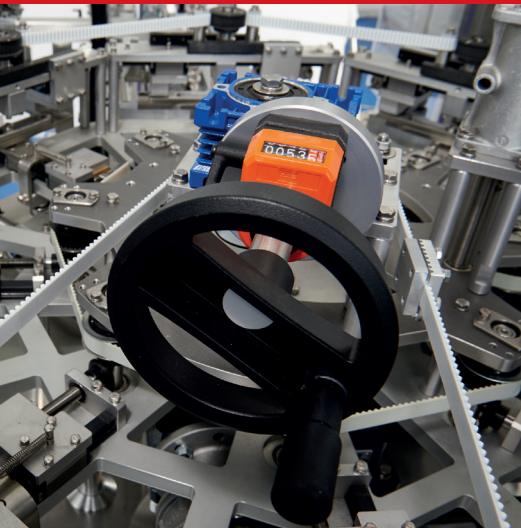



# Global representation

Shemesh Automation collaborates with teams on complex Fortune 500 projects and has gained not only a proven and trusted network to put at your disposal, but also invaluable knowledge to help drive your projects.

We share our expertise to guarantee the maximum productivity of your machinery. Our global network of sales representatives and After Sales service specialists offer you flexible and efficient support. Our highly-qualified technicians ensure a fast solution whenever and wherever you need it.

## REGIONAL HEADQUARTERS

### United Kingdom

Shemesh Automation UK Ltd  
Contact: Mr. Carl Gunaratnam

### North America

Shemesh USA Inc  
Contact: Mr. Jim Livermore

### France

Shemesh Automation France  
Contact: Ms. Nelly Desbiens

### Israel

Shemesh Automation Israel Ltd  
Contact: Mr. Luis Coronel

## OTHER OFFICES

### Spain

Shemesh Spain  
Contact: Ms. Leticia Mulet

### United Arab Emirates

Shemesh Automation UAE  
Contact: Mr. Johann Van Niekerk

### South Africa

Shemesh Automation SA  
Contact: Mr. Simon Daniels

### India

Shemesh Automation India  
Contact: Mr. Shilpan Patel

### China & Hong Kong

Shemesh Automation Asia  
Contact: Mr. Charles Yip

### Japan & Indonesia

Shemesh Automation Japan & Indonesia  
Contact: Mr. Kentaro Taguchi

### Australia & New Zealand

Shemesh Automation Australia  
& New Zealand  
Contact: Mr. Cameron McKenzie

## LATIN AMERICA

Contact: Mr. Nir Baram

## GLOBAL SALES

Contact: Mr. Luis Coronel



ATEX



ANTI-CORROSION



For all sales enquiries please contact us via [sales@shemeshautomation.com](mailto:sales@shemeshautomation.com)

# Explosion proofed & Corrosion proofed

Corrosive or alcohol-based solutions dictate that your equipment is duly fitted to professionally handle these delicate environments. Years of experience in the field made it possible for us to tailor for you the exact protection so your production is safe and stable while your people and equipment are well protected keeping your facility at the top of the range.

All of our machines are constructed using SST 304/316L, and are available with anti corrosive proprietary coating. As well as the machine base, all vital parts such as nozzles and pumps are also specially treated.



## Offices:

### United Kingdom

Shemesh Automation UK Ltd  
85 Great Portland Street  
First Floor  
London W1W 7LT  
United Kingdom  
Tel. +44 758 428 1707



### USA

Shemesh USA Inc  
1040 Centennial Street  
Green Bay  
Wisconsin 54304  
United States  
Tel: +1 920 325 0050



### Israel

Shemesh Automation Israel Ltd  
4 Ha-Sar Khayim Moshe  
Shapira St.  
Rishon Lezion 7570406  
Israel  
Tel. +972 3550 9946



### France

Shemesh Automation France  
Bopak SARL Building  
10 Rue de la Croix Belin  
Semur-en-Auxois 21140  
France  
Tel. +33 (0) 615 210 409



[www.shemeshautomation.com](http://www.shemeshautomation.com)



*Let us build your vision*